

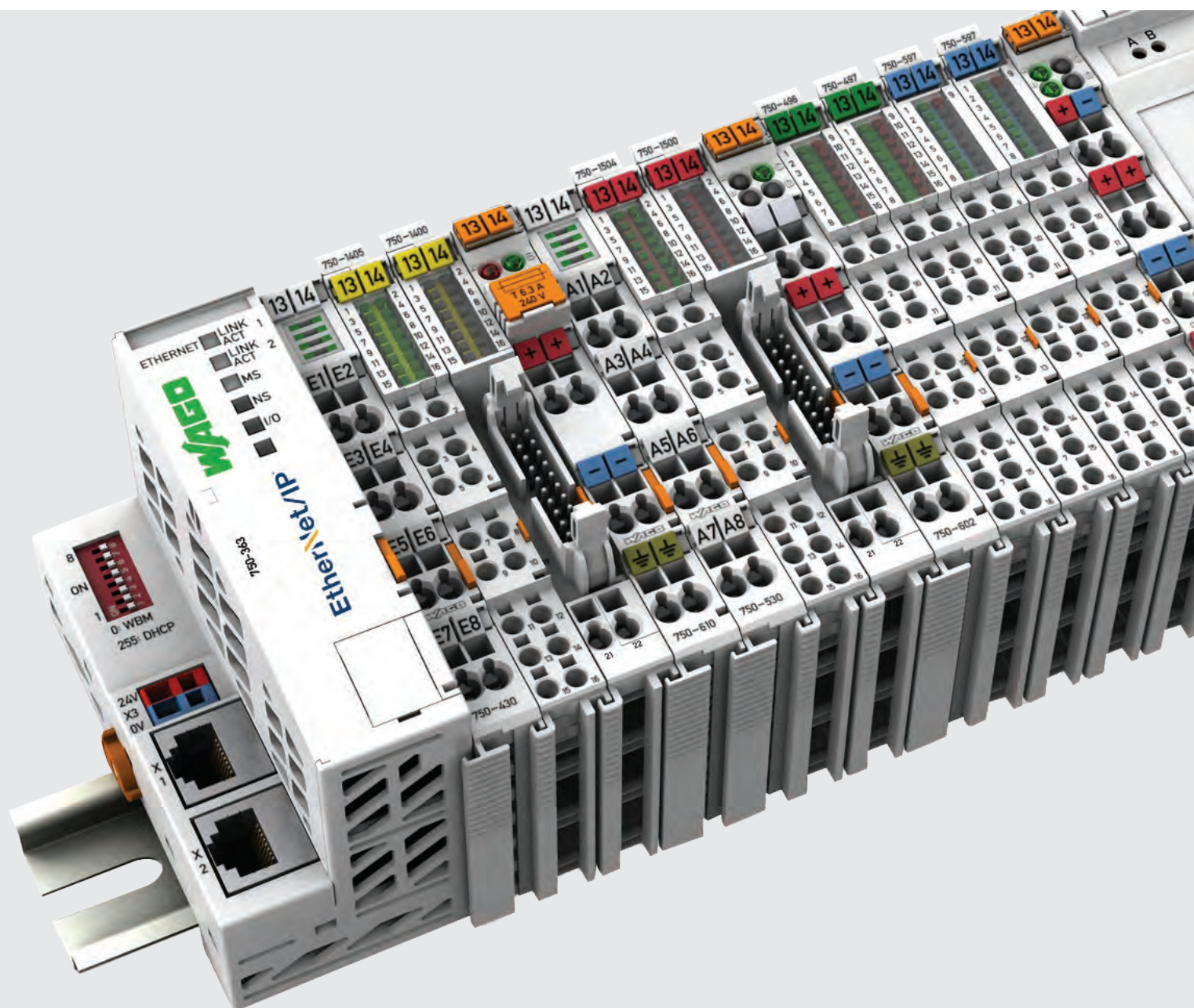

# 750 & 753 Remote I/O System

## IP20 I/O for Every Application



# REMOTE I/O

# TABLE OF CONTENTS

## 750 & 753 Remote I/O

<b>SECTIONS</b>	<b>PAGES</b>
Compelling Features.....	4
WAGO I/O System 750 .....	5
WAGO I/O System 750 XTR.....	6
Over 16 Industrial Fieldbus Protocols.....	7-10
Couplers .....	8
EtherNet /IP .....	9
Add-On Instructions .....	9
Device Level Ring .....	9
PROFINET.....	10
More Than 500 I/O Modules Available.....	11-14
3-Phase Power Measurement .....	15
Proportional Valve Module .....	16
Vibration Measurement .....	17
IO-Link Master.....	18
PWM Modules .....	19
CANopen.....	20
Software Tools .....	21-23
I/O Check Software.....	21
Ethernet Settings.....	22
Smart Printer.....	23

# Compelling Features

## Fieldbus Independent

One of the founding principles behind the WAGO-I/O-SYSTEM is fieldbus independence. As one of the first to bring this concept to industry, we now support 16+ networks. The modularity of the system allows existing WAGO-I/O-SYSTEM nodes to be converted to a different network with a simple change of the bus coupler.

## Secure and Reliable Connections

CAGE CLAMP® spring pressure wiring technology offers fast, vibration-proof, and corrosion/thermal cycling resistant wiring that is maintenance-free. No torque specs required!

## Mechanical Connection

I/O modules offer built-in power contacts for power distribution and data contacts for internal data transmission – no chassis or jumpers required.

## Compact Size

Our patented mechanical design allows for extremely compact I/O nodes. I/O modules can accommodate up to 16 channels in a 1/2 inches wide housing, while most bus couplers are only 2" wide by 4" deep.

## Maximum Flexibility

With so many options, a WAGO-I/O-SYSTEM node can be configured to meet the most difficult application requirements.

- Freely mix analog, digital and special function modules in the same node
- Supply modules allow different voltages (e.g. 24V, 120V, 230V) in the same I/O node
- Fine granularity allows optimal use of space
- Gateways to other networks – Modbus, AS-Interface, I/O Link, etc.

## Clear Identification

Ample marking and identification.

- Pullout group marker for color identification of module type (DI = yellow, DO = red, AI = green, AO = blue, special functions = clear)
- Termination marking for up to 10 WSB marker tags per module
- Color coded modules – blue for intrinsically safe and yellow for safety

## Extended Temperatures

Some applications are located in a variety of harsh environmental conditions. Therefore, the modules are designed to meet your application needs.

- Standard 32 °F to 131 °F (0 °C to 55 °C)
- Wide Temperature -4 °F to 140 °F (-20 °C to 60 °C)
- Extreme Temperatures -40 °F to 158 °F (-40 °C to 70 °C)

## Simple Handling

The chassis free, DIN rail mount design, allows for easy installation, expansion, and modification of the I/O node.

## Worldwide Standards

The exceptional reliability and quality of WAGO's components provide applications with the highest levels of technical accuracy and safety. The WAGO-I/O-SYSTEM has achieved multiple international certifications.

- Marine certifications (GL, DNV, BV, ABS)
- UL, AEx, and ATEX Hazardous locations
- Intrinsically safe



# WAGO I/O System 750

## The System for Every Application

The universal WAGO-I/O-SYSTEM 750/753 is defined by its broad application range and extensive product portfolio. With more than 500 different digital, analog, and special function I/O modules, virtually every signal type in a wide range of applications is covered.

Proven in industrial, process, and building automation, as well as SmartGrid and hazardous locations; the WAGO-I/O-SYSTEM offers the most flexible, modular and compact platform for stand alone or distributed automation. Worldwide approvals such as UL, ABS, and IECEx are examples of the system's versatility and robust design.



### Benefits

- Support of 16+ Fieldbuses – Standard fieldbus protocols and Ethernet standards
- More than 500 digital, analog and special function I/O modules
- Flexible platform adapts to diverse applications and environments
- Worldwide approvals – UL, ABS, AEx, IECEx and more
- 753 Series for pluggable wiring



# Over 16 Industrial Fieldbus Protocols

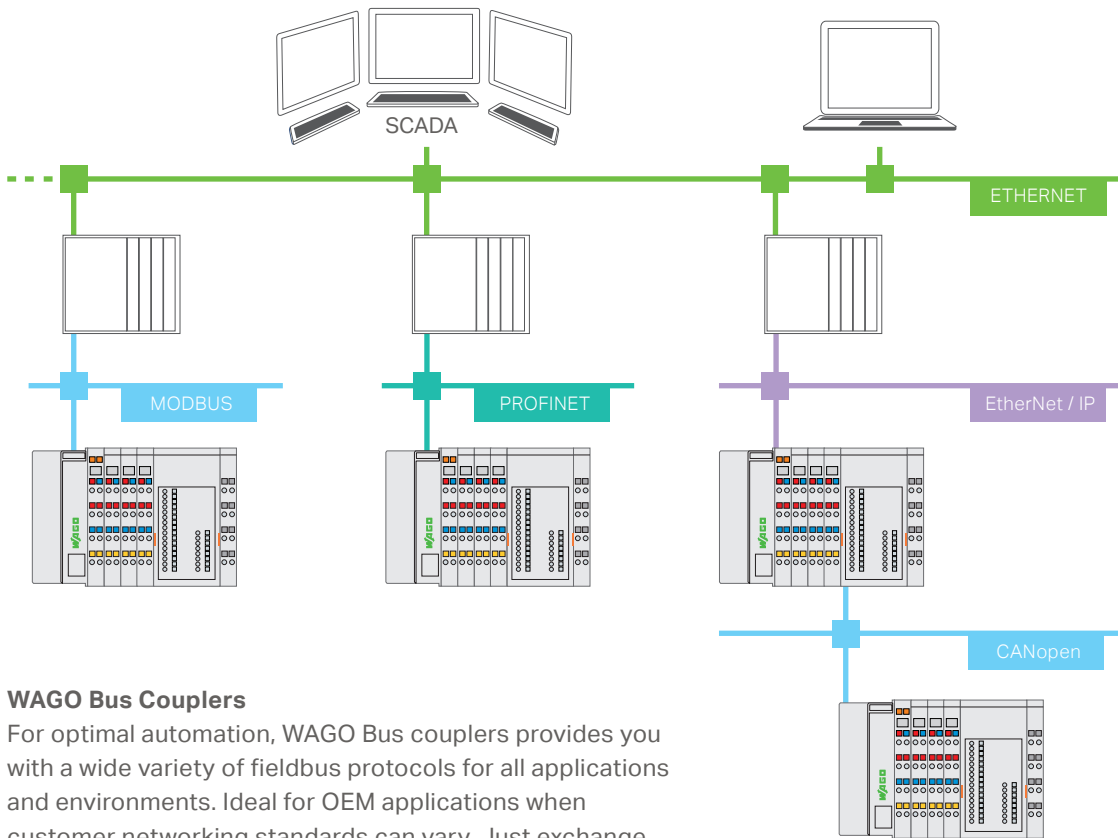

## WAGO Bus Couplers

For optimal automation, WAGO Bus couplers provides you with a wide variety of fieldbus protocols for all applications and environments. Ideal for OEM applications when customer networking standards can vary. Just exchange the coupler to support the required fieldbus protocol.

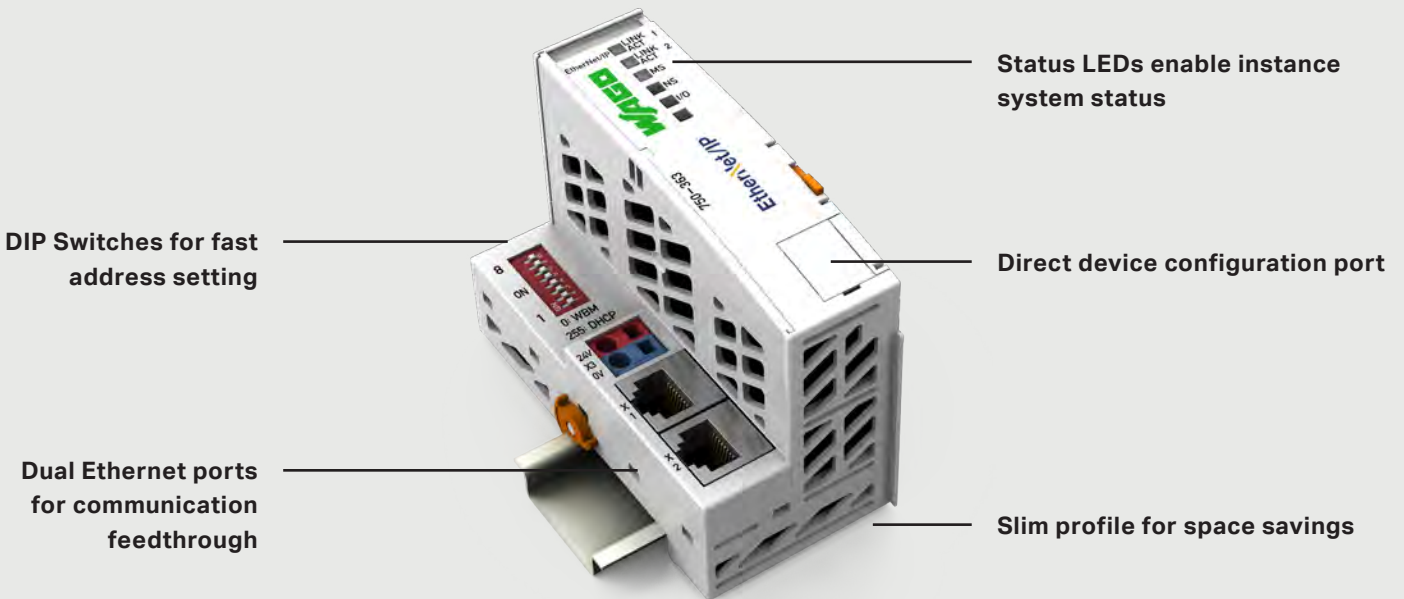

## EtherNet/IP



- DIP switch/DHCP/direct addressing
- Software-free replacement
- Redundancy via DLR

## PROFINET



- DIP switch/DHCP/direct addressing
- Software-free replacement
- Configurable I/O via GSDML
- MRP redundancy
- Compliance class C

## Modbus



- DIP switch/DHCP/direct addressing
- Software-free replacement
- Auto Recognition
- Dual Ethernet ports for communication daisy chain

## BACnet



- ECO Version
- 10kBD..1MBd Throughput
- 5 Rx PDO / 5 Tx PDO
- Setting via EDS file
- Bus continuity and termination resistor

## EtherCAT



- DIP switch/DHCP/direct addressing
- Software-free replacement
- Settings via ESI file
- EtherCAT redundancy
- EtherCAT compliance certified

## CANopen



- Standard Version
- 10kBD..1MBD Throughput
- 32 Rx PDO / 32 Tx PDO
- Bus continuity and termination resistor

# PROTOCOLS

# EtherNet/IP Solutions

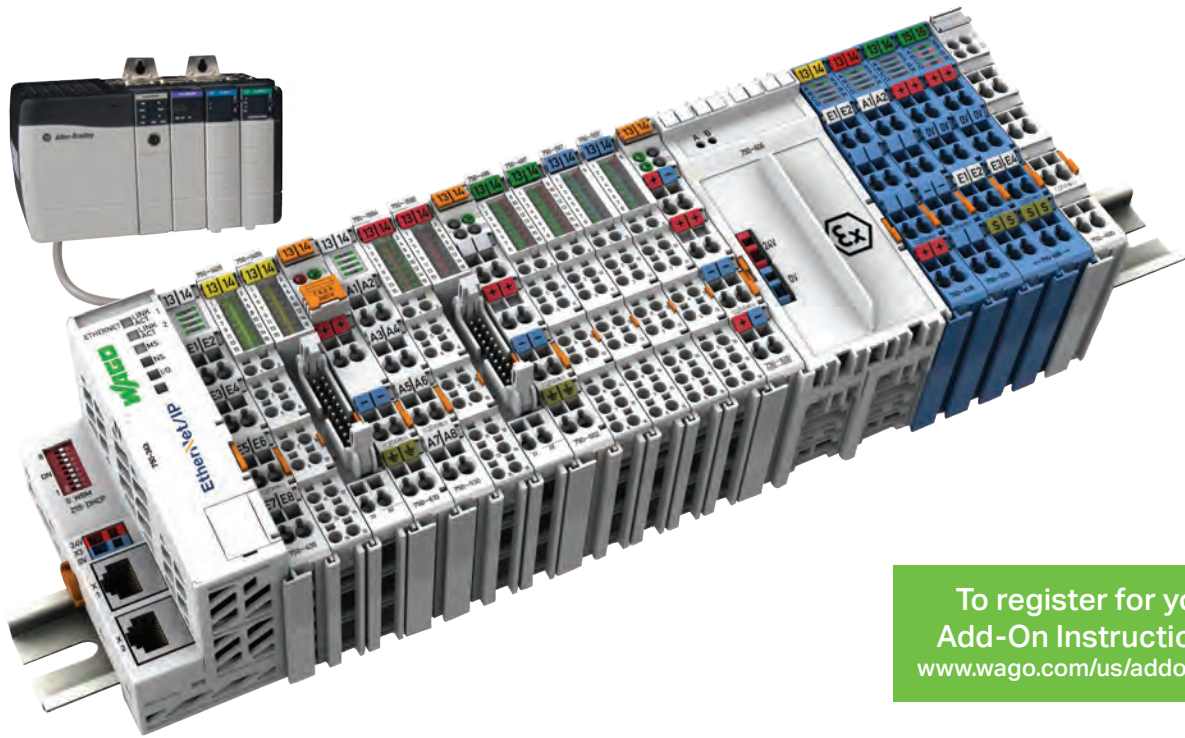

To register for your FREE Add-On Instruction file visit [www.wago.com/us/addon\\_instructions](http://www.wago.com/us/addon_instructions)

## Upgrade your Allen-Bradley® RSLogix™ System with Add-On Instructions

WAGO's Add-On Instruction (AOIs) program is an easy way to increase the capabilities, as well as reduce the costs, of an Allen-Bradley® RSLogix™ system. Our predefined AOIs provide the variables and logic for WAGO-I/O-SYSTEM modules and are easily placed within an RSLogix™ program – reducing engineering time. While our special function I/O modules increase the application range, our standard I/O modules further enhance the system by reducing its foot print,

increasing flexibility, and are typically more cost-effective than expansion racks or system I/O. You can also extend your system into extreme environments with our 750 XTR line of I/O, engineered for -40 ° F to +158 ° F operating temperatures plus resistant to condensation and high vibration.

### Required Tools

- RSLogix 5000® Software (version 16 and up)
- WAGO predefined AOI XML file

### Three Easy Steps

1. Open the import feature in RSLogix 5000®
2. Select correct Add-On Instruction XML file
3. Insert Add-On Instructions into your PLC logic

All that is left is to establish the parameters required for your application!

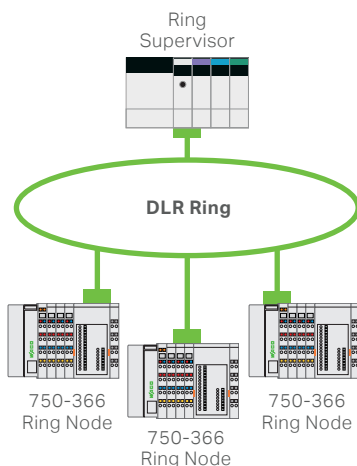

In a Device Level Ring or DLR topology, one communication path is artificially disconnected to prevent a ring loop or flood of the network. A ring supervisor monitors the ring by sending Beacon Frames, at particular intervals, across the network. If these Beacon Frames are not received back before the allotted time out, the supervisor assumes there is a disconnect and the previous artificially closed port will be reopened allowing traffic to resume. This reconnection occurs within a few milliseconds on a properly configured DLR network and therefore eliminates interruptions in an application due to single point cabling or participant failures.

# PROFINET



## PROFINET from WAGO

WAGO couplers feature standard PROFINET features such as extensive diagnostic capabilities and topology detection for fast device replacement without programming tools. They also provide added features that include an integrated 2-port switch which allows a line topology to be implemented without additional components. It also includes SNMP to check the capacity of both ports, error statistics, or type and number of transmitted telegrams

WAGO's PROFINET I/O and PROFINET I/O ECO Fieldbus Couplers can also be used in energy management systems. Operating costs can be reduced via the PROFInergy profile, allowing individual parts of your automation systems to be switched on and off automatically during breaks or downtime.

For safety-related applications, fail-safe modules can be connected to the couplers using the PROFIsafe protocol V2 for data transmission. In the event of maintenance, the iPar server function provides parameter backup for the connected modules. Data is transmitted automatically to the yellow modules via a standardized iPar server.



# More than 500 I/O Modules Available

## 1-,2-,4-, and 16-Channel

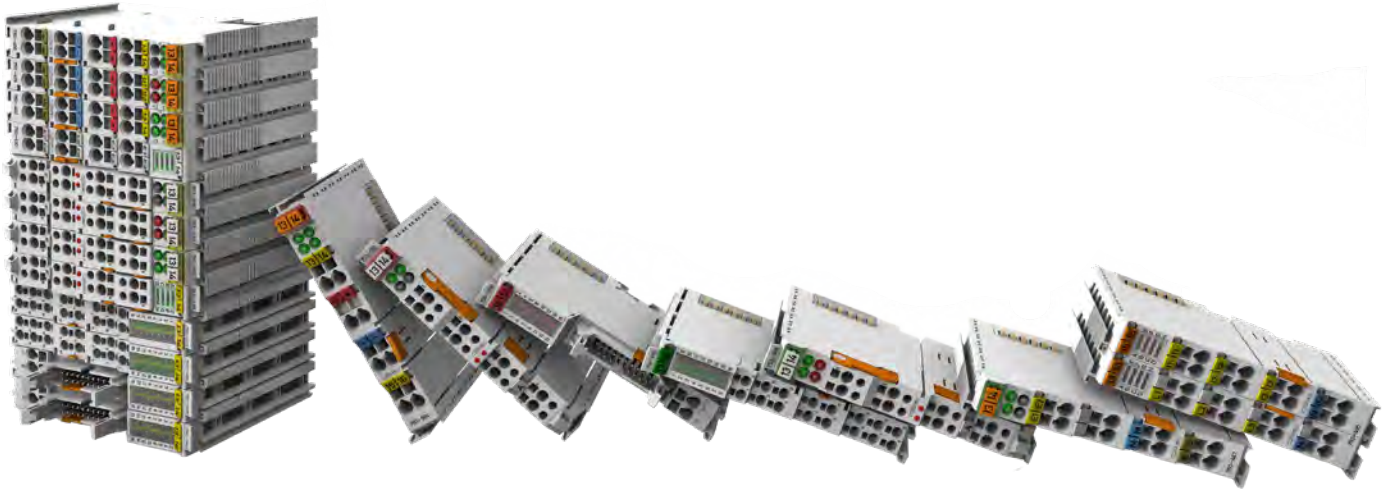

### Digital Input Modules

#### 2-Channel Digital Input

- 24, 48, 60, 110, 220 VDC
- 120, 230 VAC
- NPN/PNP, 0.2 ms/3.0 ms, filter, diagnostics

#### 2-Channel Specialty Modules

- NAMUR
- Pulse extension
- Intruder detection
- Up/down counter, 500 Hz, 100 kHz

#### 4-Channel Digital Input

- 5, 24, 42 VDC
- 24, 42 VAC, 110 ... 230 VAC

#### 8-Channel Digital Input

- 24 VDC, 5 ... 14 VDC
- NPN/PNP, 0.2/3.0 ms, filter
- PTC

#### 16-Channel Digital Input

- Push-in CAGE CLAMP®, 24 VDC, NPN/PNP
- Ribbon cable, 24 VDC, NPN/PNP

### Digital Output Modules

#### 1-Channel Digital Output

- 440 VAC, 16 A
- Manual operation, bistable

#### 2-Channel Digital Output

- 24 VDC, 0.5 A/2 A, diagnostics (broken wire/short circuit)
- 230 VAC, SSR, 3.0 A, diagnostics

#### 4-Channel Digital Output

- DC 5 V, 24 V, 0.5 A
- 5, 24 VDC, 30 VAC/DC, 0.5/2 A
- 120 ... 230 VAC, 0.25 A
- NPN/PNP, diagnostics

#### 8-Channel Digital Output

- 5 ... 14 VDC, 1 A
- 24 VDC, 0.5 A
- NPN/PNP, diagnostics

#### 16-Channel Digital Output

- Push-in CAGE CLAMP®, 24 VDC, 0.5 A, NPN/PNP
- Ribbon cable, 24 VDC, 0.5 A

#### 2-Channel Relay Output

- 0 ... 230 VAC/DC
- 2 make contacts/2 changeover contacts, isolated outputs/non-floating

#### 4-Channel Relay Output

- 4 make contacts

### Analog Input Modules

#### 2-Channel Analog Input

- Resistor bridge (strain gauge)
- AC/DC 0/4 ... 20 mA, 0 ... 1/5 A
- DC 0 ... 10 V,  $\pm 10$  V, 0 ... 30 V
- Thermocouples
- Resistance measurement (RTD)
- Differential/single-ended input
- Measurement input (electrical isolation)
- Modules with HART protocol (NE43)

#### 4-Channel Analog Input

- 0/4 ... 20 mA
- 3, 6 ... 21 mA NE43
- $\pm 20$  mA
- 0 ... 10 V,  $\pm 10$  V
- Resistance measurement (RTD)
- Differential/single-ended input
- Diagnostics
- Measurement input (electrical isolation)

#### 8-Channel Analog Input

- 0 ... 10 V /  $\pm 10$  V
- 0/4 ... 20 mA
- Thermocouples
- Resistance measurement (RTD)
- Single-ended input
- Push-in CAGE-CLAMP® connection technology

#### 3-Phase Power Measurement

- 480 / 690 V, medium voltage, 1 A / 5 A/Rogowski coil



## Analog Output Modules

### 2-Channel Analog Output

- 0 ... 10 V /  $\pm 10$  V
- 0/4 ... 20 mA

### 4-Channel Analog Output

- 0 ... 10 V /  $\pm 10$  V
- 0/4 ... 20 mA

### 8-Channel Analog Output

- 0 ... 10 V /  $\pm 10$  V

### Analog Specialty Modules

- 6 ... 18 V
- 0 ... 10 V, 10 mA, diagnostics



## Function and Technology modules

### Counter Modules

- Up/down counter
- Frequency counter
- Peak-time counter

### Distance and Angle Measurement

- SSI transmitter interface
- Incremental encoder interface
- Digital impulse interface

### Positioning

- Stepper controller, RS-422
- Stepper controller, 24 V/1.5 A
- Stepper controller, 70 V/7.5 A, 6IN/2OUT
- Servo stepper controller, 70 V/7.5 A, 6IN/2OUT
- DC drive controller, 24 V/5 A

### Pulse Width Output

### Proportional Valve Module

- Control of hydraulic or pneumatic valves

### Vibration Monitoring

- Vibration velocity/bearing condition monitoring



# A Wide Variety of I/O Modules

For Virtually Any Application



## Communication Modules

### Building Automation

- DALI Multi-Master
- EnOcean® Radio Receiver
- MP-Bus
- KNX/EIB/TP1 Interface
- LON®
- SMI
- M-Bus

### Serial Interfaces

- RS-232-/RS-485 interface (configurable)

### 4-channel IO-Link Master

### AS-Interface Master

- Per (M4) V 3.0 specification
- Up to 62 slaves

### CAN Gateway

## Functional Safety

### Fail-Safe Digital Input PROFIsafe

- 4FDI, 24 VDC
- 8FDI, 24 VDC

### Fail-Safe Digital Input/Output PROFIsafe

- 4FDI/2FDO, 24 VDC, 10 A
- 4FDI/4FDO, 24 VDC, 2 A
- 4FDI/4FRO, 48 VAC, 60 VDC, 6 A

### Intrinsically Safe Digital Input PROFIsafe

- 4 F Ex i DI, 24 VDC, Zone 0 + 1

### Fail-Safe Analog Input PROFIsafe

- 4FAI 0/4 ... 20 mA

### Safety Category

- PLe/Cat. 4 to EN ISO 13849 or SIL 3
- EN IEC 62061

## Supply and Segment Modules

### Local Bus Extension

- End Module
- Coupler Module

### Supply Module

- 0 ... 230 VAC/DC
- Fuse/diagnostics (optional)
- 24 VDC/5 ... 15 VDC (adjustable)

### Filter Module

- System and field supply
- 24 VDC power supply filter with overvoltage (surge) protection

### Potential Distribution Module

- 24 VDC
- 0 VDC

### Distance Module

- 24 VDC / 230 VAC

### End Module



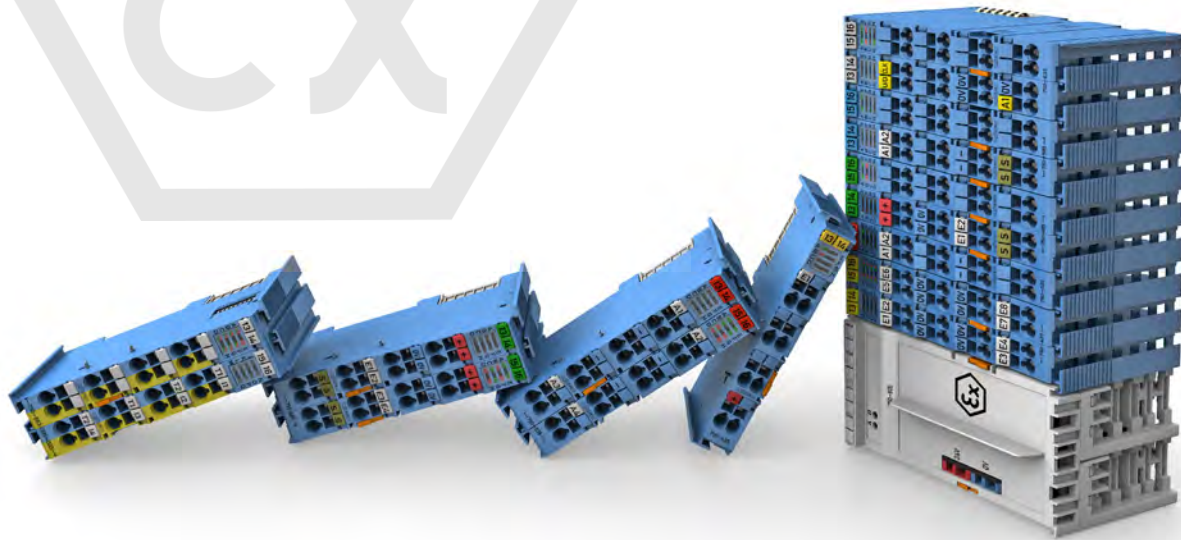

## Intrinsic Safety

### 1-Channel Digital Input

- NAMUR

### 2-Channel Digital Input

- NAMUR

### 4-Channel Digital Input

- PROFIsafe

### 8-Channel Digital Input

- NAMUR

### 2-Channel Digital Output

- Max. 40 mA

### 4-Channel Digital Output

- Valves

### 2-Channel Relay Output

- 2 changeover contacts

### 2-Channel Analog Input

- 4 ... 20 mA
- 4 ... 20 mA, HART (NE43)

### 4-Channel Analog Input

- 0/4 ... 20 mA, 3.6 ... 21 mA (NE43)
- Resistance measurement (RTD)
- Thermocouples (TCs)
- Strain gauges (DMS)

### 2-Channel Analog Output

- 0 ... 20 mA
- 4 ... 20 mA

### Up/Down Counter

- 20 ... 50 kHz

### Supply Module

- 24 VDC, 1 A



NAMUR HART AEx

# 3-Phase Power Measurement

The 750-495 3-Phase Power Measurement module allows measurement of electrical data in a 3-phase supply network. The I/O module provides a variety of measured and calculated quantities as well as allowing comprehensive analysis of the supply network. These measured values allow the operator optimized control of the supply to a drive or machine, protecting the system from damage and failure. The measured values indicate the load type (inductive or capacitive) and whether it is an energy consumer or producer, for example. This allows visualization as a four-quadrant display, as has been implemented in the display of the measured values in WAGO-I/O-CHECK, among other things.

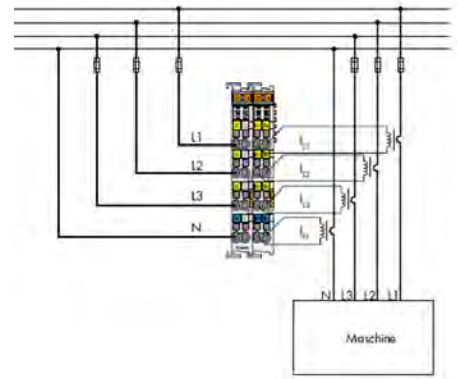

On the basis of these input signals, the I/O module determines the various AC measured quantities, such as voltage and current, reactive, apparent and active power, energy consumption, power factor, phase angle and frequency. Harmonic analysis (current/voltage) is also possible for a selectable phase up to the 41st harmonic. The measured quantities are available in the process image without requiring high processing power from the controller.

- "4-Wire Wye" ("4-W"): Standard measurement topology for networks with neutral conductor; enables power measurement in single-phase, 3-phase and single-phase split phase networks.
- "3-Wire Wye/Delta" ("3-W"): For 3-phase networks without a neutral conductor; also referred to as "Aron circuit", "Blondel theorem" and "2-wattmeter method."
- "4-Wire Wye, 2-Phase" ("4-W/2-W"): Measurement topology for 3-phase networks with neutral conductor in which the voltage measurement of phase L2 can be omitted, whereby wiring effort is reduced compared to the "4-Wire Wye" measurement topology. The corresponding measured values are automatically calculated by the I/O module.

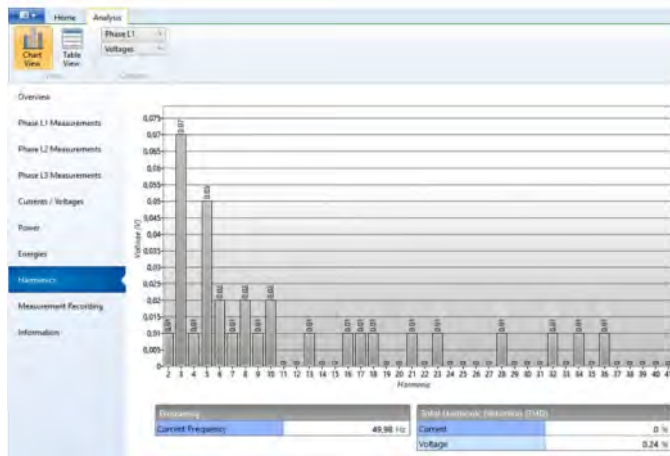

"Artificial Star Point" (ASP) is a measurement topology used when no neutral conductor or grounded phase is available. By configuring input impedances to create an ASP within the module, it acts as a virtual neutral point for voltage measurements. This allows for accurate voltage assessment in delta-configured systems without altering the physical network. ASP is ideal for enhancing measurement capabilities in systems lacking a true neutral but is unsuitable for networks with an existing neutral or grounded phase.

# 3-PHASES

# Proportional Valve Module

750-1632/000-100

The 750-1632/000-100 Proportional Valve Module controls two single-coil valves with up to 24 V/1.6 A or one valve with up to 24 V/2 A. The module features two current-controlled PWM\* outputs with adjustable dithering.

Both unipolar and bipolar valve control are possible. Additionally, operation of a valve with two unipolar coils is also provided. A two-channel module may also be used for simple applications. Characteristic curve adaptations, such as zero offset, dual gain compensation or range limitations, can be adjusted via parameters.

Scaling and configurable up/down ramps permit set point adjustment to the application. For example, monitoring threshold value switches is performed via two additional digital inputs. Start-up and valve parameters adjustment are performed via WAGO-I/O-CHECK software or the controller.

\*PWM = Pulse width modulation



## Features

- 2 current controlled (PWM) outputs for 24V DC
- Current rating up to 1.6 A (2 channels) and 2.0 A(1 channel)
- Controlling of one coil and two coil valves
- Unipolar or bipolar coils connectable
- Dead zone compensation and linearization
- Selectable & adjustable dither
- 2 configurable inputs (IEC 61131, type 1)

## Benefits

- Comprehensive control of hydraulic and pneumatic proportional valves
- Connectable to many field busses
- Control of 2 valves inside 12mm!
- Reduce system components and footprint
- Reduce wiring
- Easily configuration via WAGO IOCHECK
- Configurable for multiple types of valves and coils
- Adjustable current profiles
- UL and CE certification
- Excellent price to performance ratio

# Vibration Measurement 750-645

The 750-645 offers two methods of analyzing vibration. One method is the Shock Pulse Method (SPM), used throughout industry for several applications but it is optimized for applications where two metal parts come in contact with each other, as commonly found in roller bearings.

The 750-645 vibration monitor uses a Tandem-Piezo Electric sensor to monitor the two vibration indicators used in SPM measurements:

- **Carpet** – the basic noise of a bearing and directly corresponds to lubrication thickness
- **Shock Impulses** – these are momentary and result from mechanical damage to bearing surfaces.

Analyzing the information from these two values can help detect arising problems with a bearing, such as insufficient lubrication or foreign matter in the bearing. The graphs at the left show examples of how SPM uses carpet and peak shock impulses to classify the operating condition of equipment.

The other option for analyzing vibration is monitoring the vibration velocity as this relates to machine fatigue. The frequency range is selected based on the machines RPM: 2 Hz to 1000 Hz for greater than 120 RPM, 10 Hz to 1000 Hz for greater than 600 RPM.

The 750-645 module reports velocity in mm/s root mean square (RMS). This value can be compared with the ISO 10816-3 standards for classifying the status of the machines operating condition. This standard defines four groups of conditions: Newly Commissioned, Long-Term Operating Admissible, Short-Term Admissible and Vibration Causing Damage.

## Monitor

- Motors
- Bearings
- Pumps
- And more!

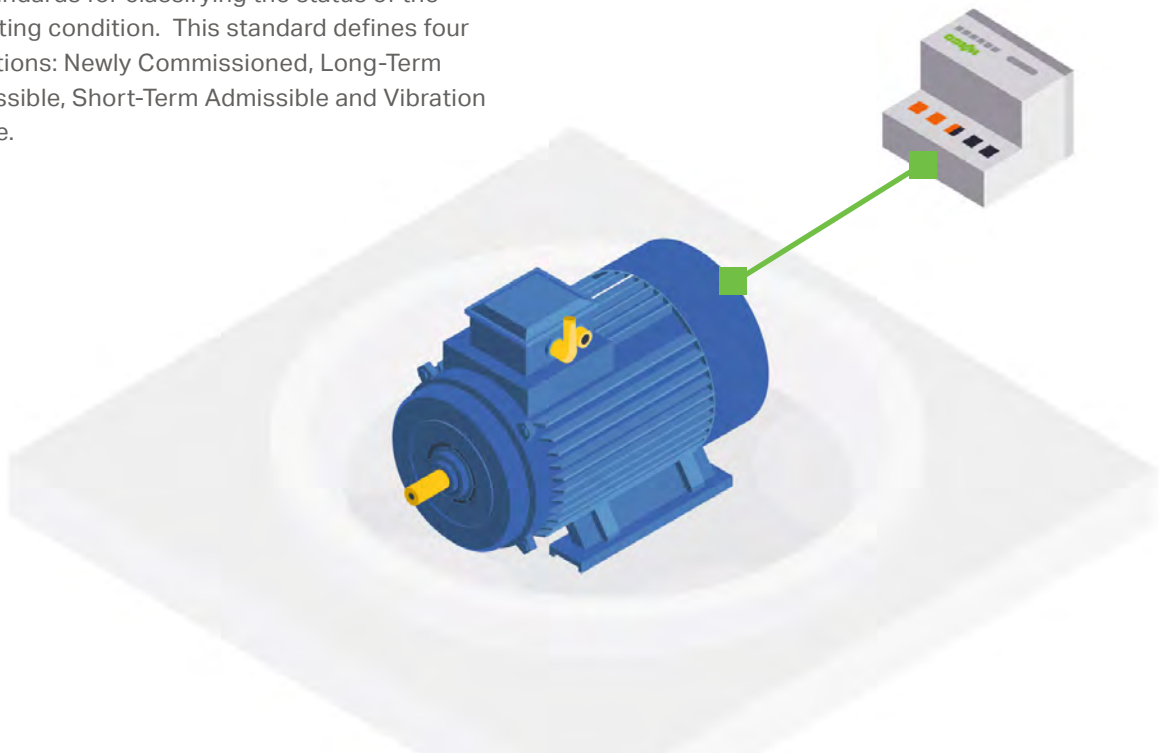
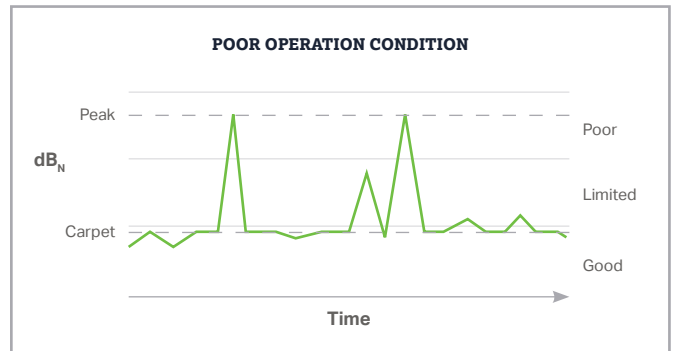
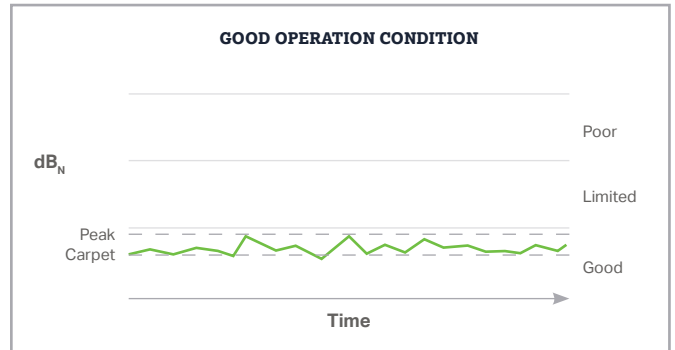

# IO-Link Master 750-1657

Increasingly complex products, manufacturing flexibility, and high demands on quality assurance require intelligent, configurable, and programmable sensors. To fulfill these demands, IO-Link streamlines the varying interfaces required to connect to a control system and tooling.

A 3-wire connection can communicate process data as single bits, bytes, and data blocks for input and output data. It also communicates acyclic data for identification, configuration, parameterization, and diagnostics with up to 230.4 kBaud to both sensors and actuators.

The functions and performance data are defined via device description files for the IO-Link devices and can be easily customized via WAGO I/O-CHECK or the WAGO IO-Link Configurator. If a device must be replaced, the configuration and parameterization can be automatically restored without maintenance personnel. This makes project design, installation, and operation considerably simpler!

Four different IO-Link devices, or even digital standard sensors/actuators, can connect to the WAGO 750-1657 IO-Link Master simultaneously.

## Save time and money due to:

- Standardized interfaces for simple device communication
- Easy configuration
- Consistent wiring
- Independent of the recorded data
- Additional information (diagnostics, quality assurance)
- Small spatial requirements
- One tool for all devices
- Easy to use due to IODD device descriptions
- Reduce training costs
- Less training required
- Compatible with all relevant fieldbus systems

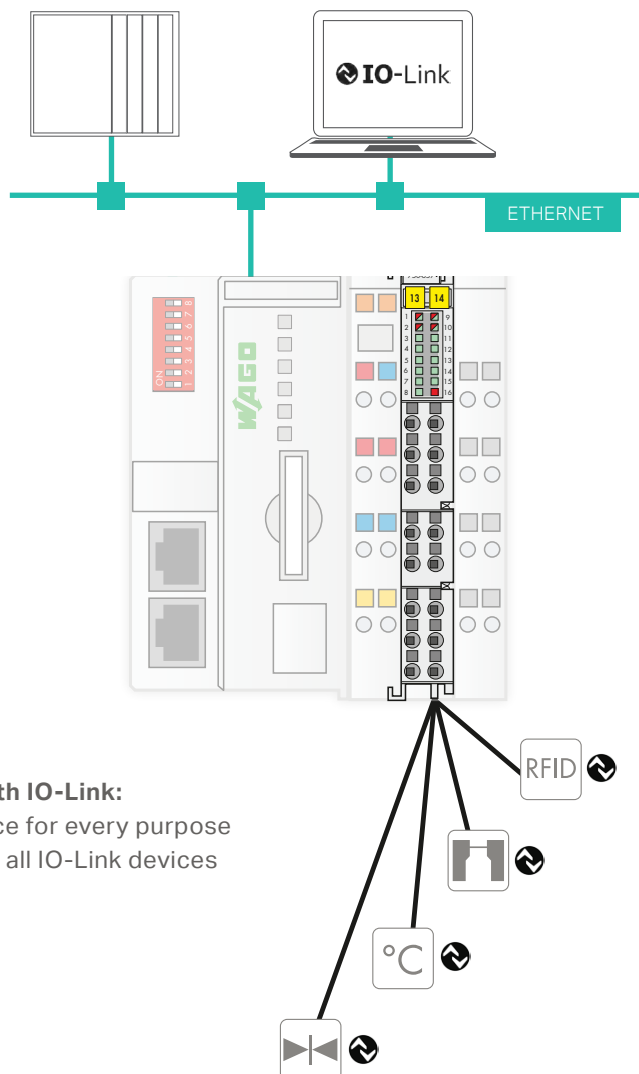

### The solution with IO-Link:

- One interface for every purpose
- One tool for all IO-Link devices

# PWM Modules 750-677

**A new module for pulse width modulation (PWM) offers greater flexibility and allows more applications.**

The 4-channel pulse width modulation module for the WAGO I/O System 750 is only 12 mm wide, but can control up to four channels and switch between five operating modes. That opens up more possible applications – especially for instrument and control engineering users – saves space and reduces costs. The module also offers a current carrying capacity of 0.2 A per channel, which can be increased to 0.4 A through parallel connection, and a switching frequency up to 20 kHz. Flexible switching between operating modes is possible, for instance, between a variable duty cycle and variable frequency. With this, the same module can be used for different kinds of PWM control. For example, in heating control, the new PWM module allows precise readjustment instead of just two-point control. As an XTR version for extreme environments (Item No. 750-677/040-000), the module can also meet more challenging requirements, such as extreme temperature resistance, increased dielectric strength and high vibration and shock resistance.

## Item Numbers:

- 750-677
- 750-677/040-000 (XTR version)

## The I/O module has 5 operating modes:

1. PWM DC: Duty Cycle Variables
2. PWM Frq: Frequency Variable
3. PWM Frq-Cnt: Variable Frequency / Adjustable Duty Cycle / Counter
4. Pulse Frq-Cnt: Variable Frequency / Adjustable Pulse Width / Counter
5. PWM Pulse-Dir: Variable Number of Pulses / Frequency and Duty Cycle Adjustable / Counter

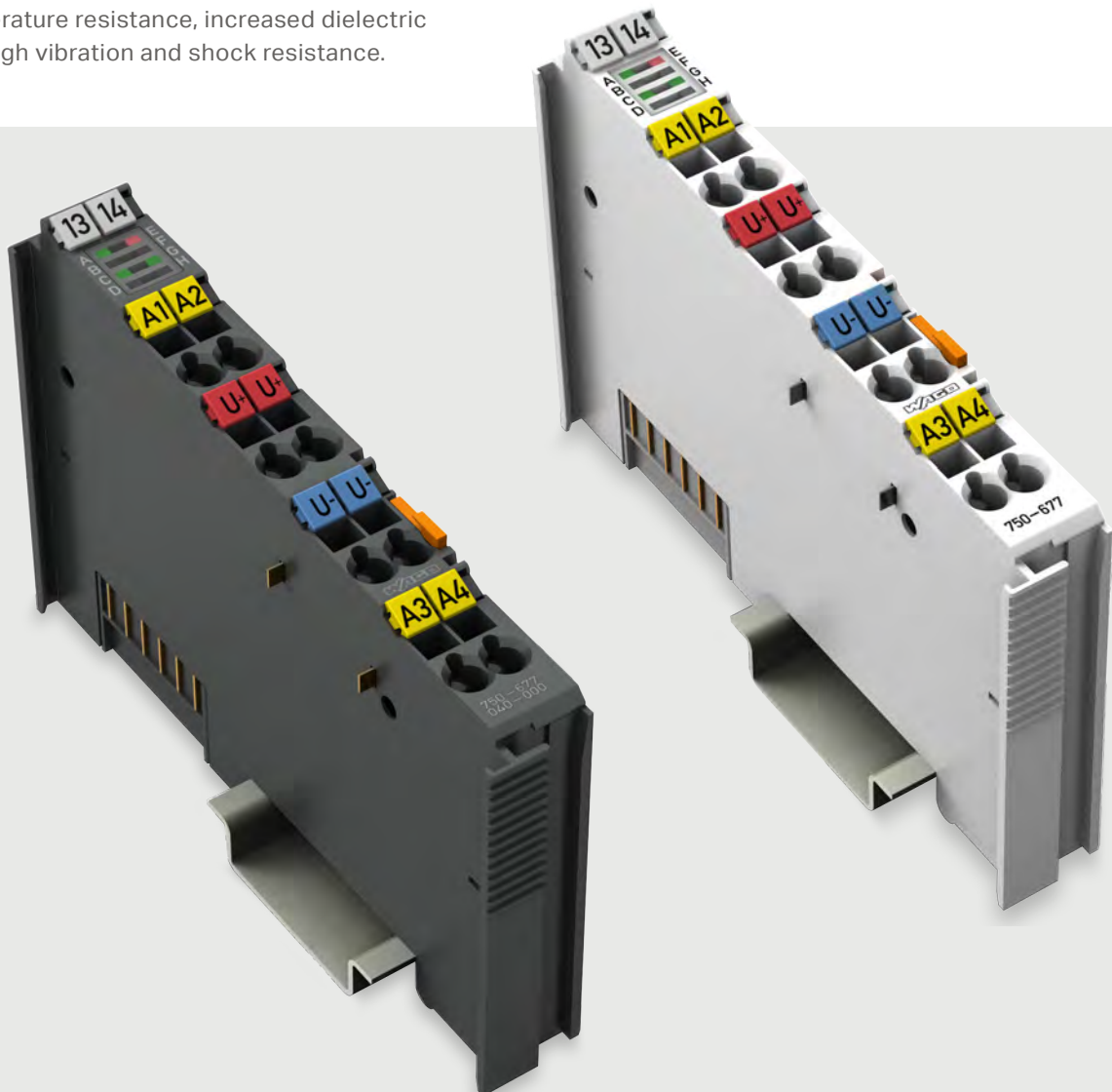

# CANopen 750-658

The CAN-bus is an asynchronous serial bus system for connecting intelligent actuators and sensors to the control level.

The module can be configured to operate in one of three operation modes:

- **Mapped Mode** – The module can be configured to receive (or send) specific telegrams from the CAN network. The received information is mapped directly in the couplers (or controllers) process image.
- **Sniffer Mode** – The module acts as a passive device on the network and can only receive CAN telegrams.

The SAE J1939 protocol is used by many large diesel engine manufacturers for data exchange including RPM, fuel consumption, temperature, oil pressure and much more.

J1939 uses telegrams that have a 29 bit header.

The 750-658 module is able to read these telegrams and either store the values in the process image of a coupler, or to be utilized by a WAGO programmable controller.

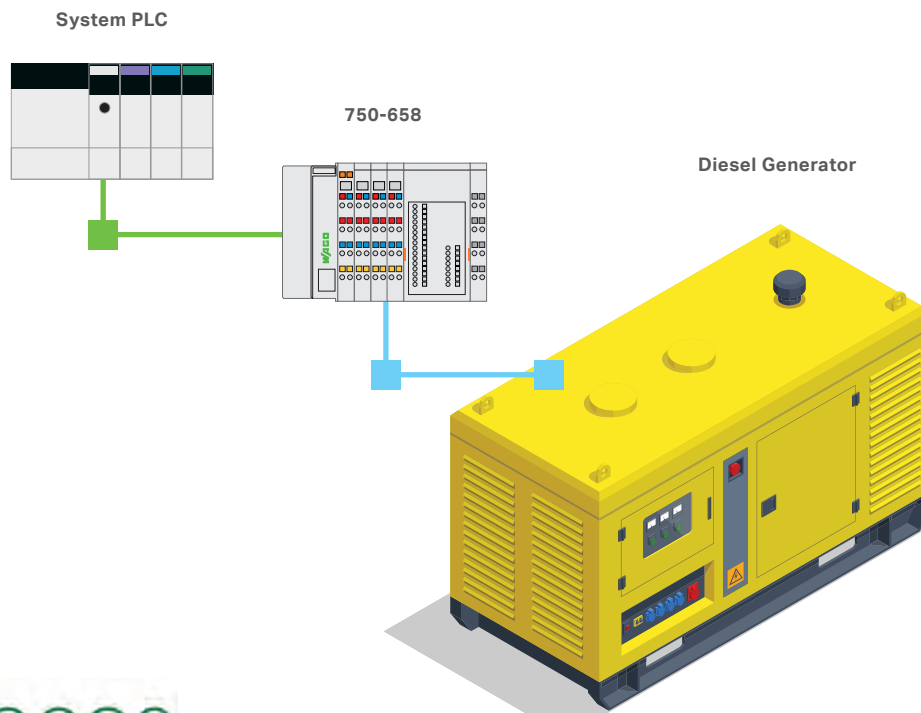

# I/O Check Software

759-302/000-923

WAGO-I/O-CHECK is an easy-to-use Windows application for operating and displaying a WAGO I/O System 750's node without connecting to a fieldbus system.

The software reads the configuration from the node and displays it graphically on the screen.

With WAGO-I/O-CHECK, it is possible to display and specify the process data of the I/O modules. You can setup WAGOs versatile configurable modules with this software tool.

The software is invaluable during system commissioning, empowering you to quickly test field wiring, including all sensors and actuators, via the software to help ensure the system is wired properly.

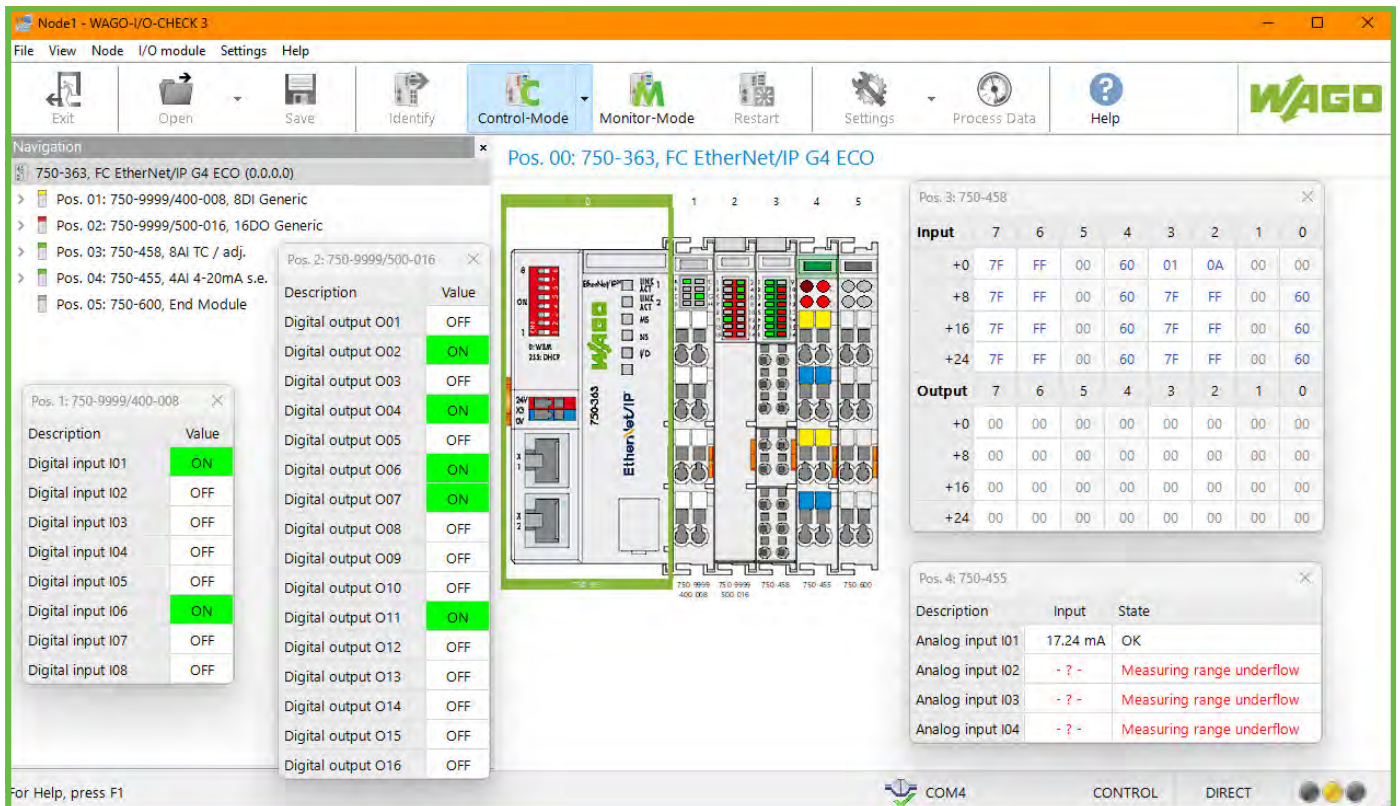

# Ethernet Settings

WAGO Ethernet Settings is a configuration tool for IP address assessment and basic settings of WAGO's Fieldbus couplers. Device connection is either via Ethernet or USB via service interface. The application can be downloaded via WAGO's Download Center.

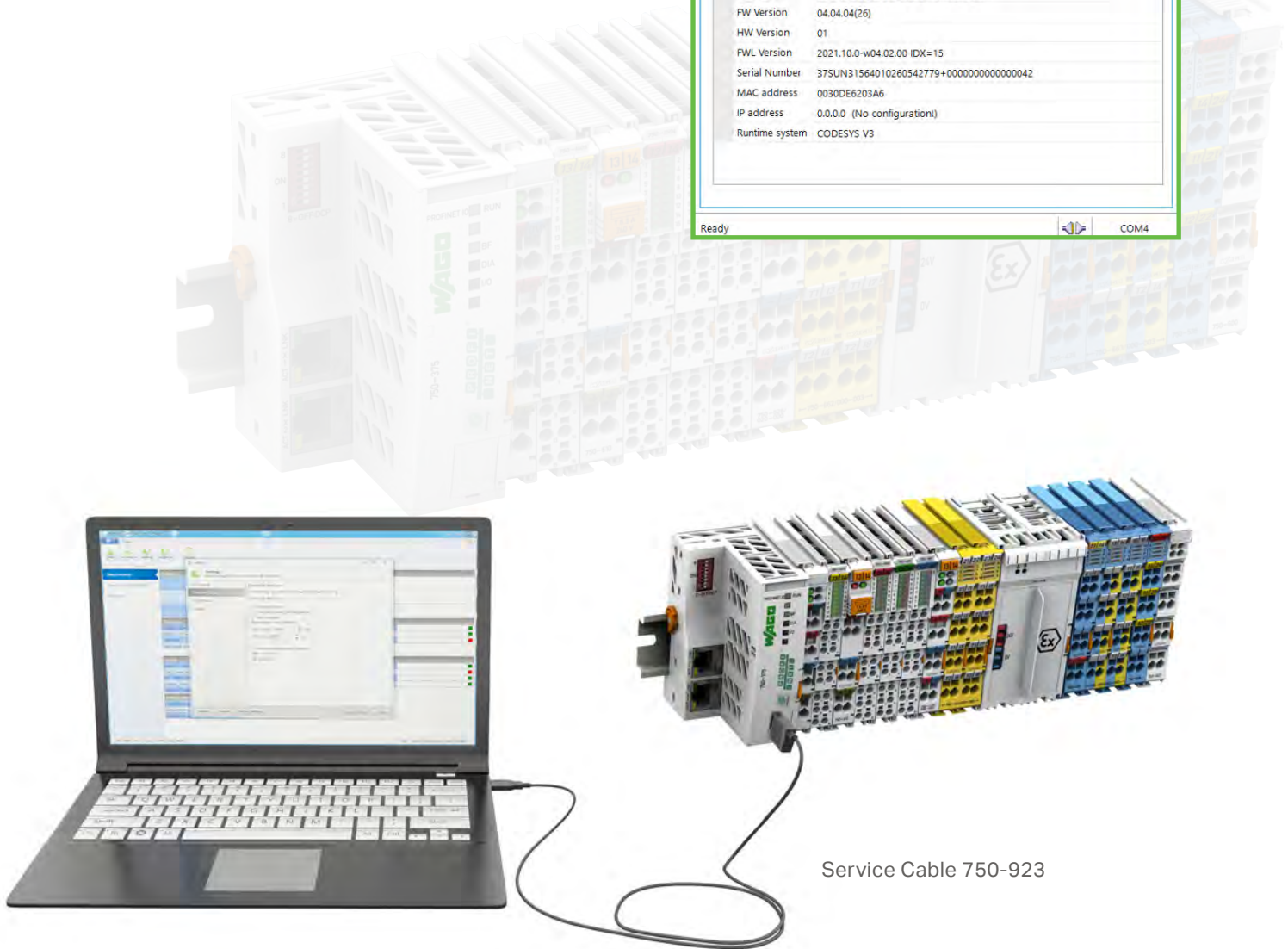
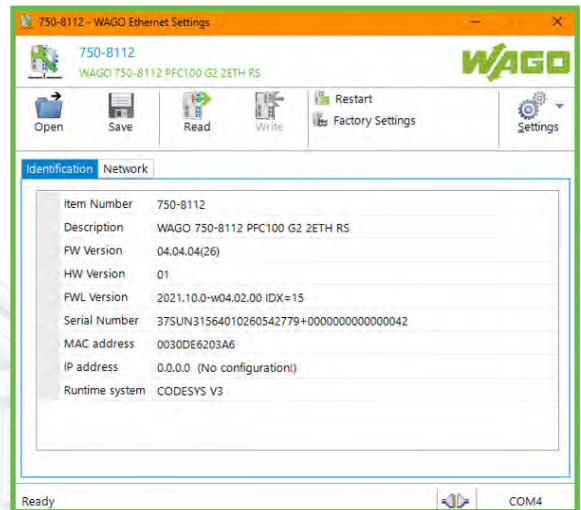

Service Cable 750-923

# Smart Designer

## Free Web-based Engineering Tool

In the age of IIoT Industry 4.0, complexity and customization of products, as well as the need for specialist expertise is increasing. At the same time, cost pressures are rising and companies are finding their quality and price priorities in conflict. Besides the

expertise of its employees and the features of its products or services, a company's ability to compete ultimately is determined by the effectiveness and efficiency of its production processes. To support its customers on the path to greater efficiency, WAGO offers smart DATA

Engineering, with a multitude of data and services focused on custom products and solutions. This enables consistent data storage and prevents system failures in different facilities, which could lead to multiple iterations and significant added expense.

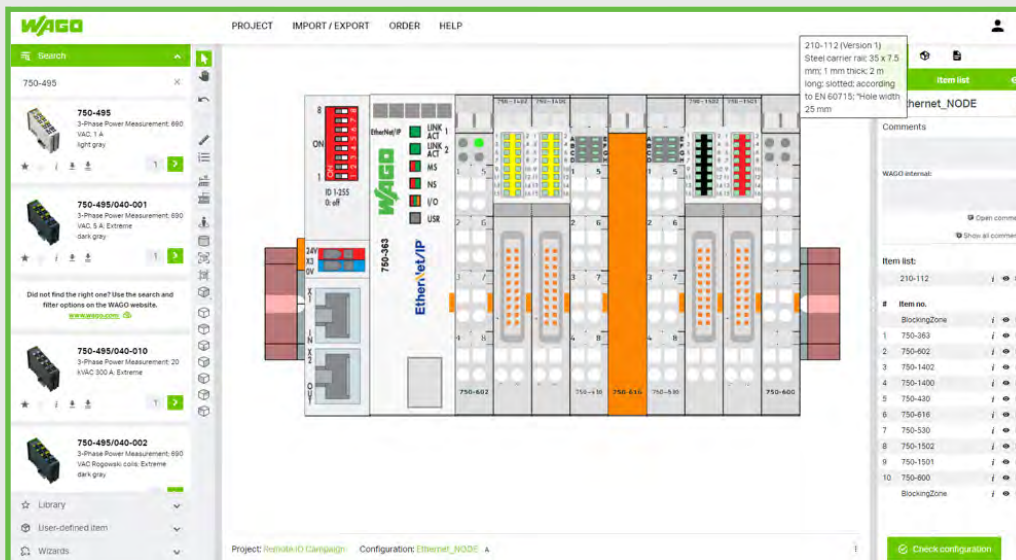

Free 3D online configuration tool



[configurator.wago.com](https://configurator.wago.com)

**WAGO Corporation**

N120 W19129 Freistadt Road  
Germantown, Wisconsin 53022  
Telephone: 800 / DIN-Rail (346-7245)  
Fax: 262 / 255-3232  
info.us@wago.com  
www.wago.us

**WAGO Canada Inc.**

1550 Yorkton Court, Unit 1  
Burlington, ON  
L7P 5B7  
Telephone: 888 / WAGO 221 (924-6221)  
info.ca@wago.com  
www.wago.ca

**WAGO SA DE CV**

Carretera estatal 431 Km. 2+200. Lote 99 6  
Parque Industrial Tecnológico Innovación Querétaro  
El Marques, Qro. 76246  
Lada sin Costo: 01 800 288 WAGO (288-9246)  
Telefono: 422 / 221-5946  
info.mx@wago.com  
www.wago.mx

WAGO is a registered trademark of WAGO Verwaltungsgesellschaft mbH.

"Copyright – WAGO Kontakttechnik GmbH & Co. KG – all rights reserved. The content and structure of the WAGO Websites, catalogs, videos, and other WAGO media are subject to copyright. The dissemination or changing of the content of these pages and videos is not permitted. Furthermore, the content may neither be copied nor made available to third parties for commercial purposes. Also subject to copyright are the images and videos that were made available to WAGO Kontakttechnik GmbH & Co. KG by third parties."